

Single-Point Diamond Dresser

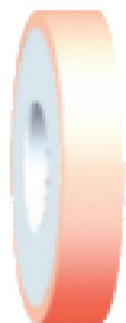

Products are mainly used in the manufacturing of automobile parts, engines and accessories, molds, and various precision mechanical parts. It is suitable for grinding wheel grinding of ordinary cylindrical grinder, centerless grinder, surface grinder, internal grinder, various special grinders and some CNC grinders.

Types Of Grinding Wheels Dressing



Parallel



One Side Tapered



External Arc



Double Hypotenuse

Product Display

Code	Grade	Shape	Schematic Diagram	Surface Roughness Grade Of The Grinding Workpiece
T	Elite grade	Octahedron		0.2
A	1st grade	Hexahedron		0.2-0.4
B	2nd grade	Polyhedron		0.4-0.8
C	3rd grade	Polyhedron		about Ra0.8

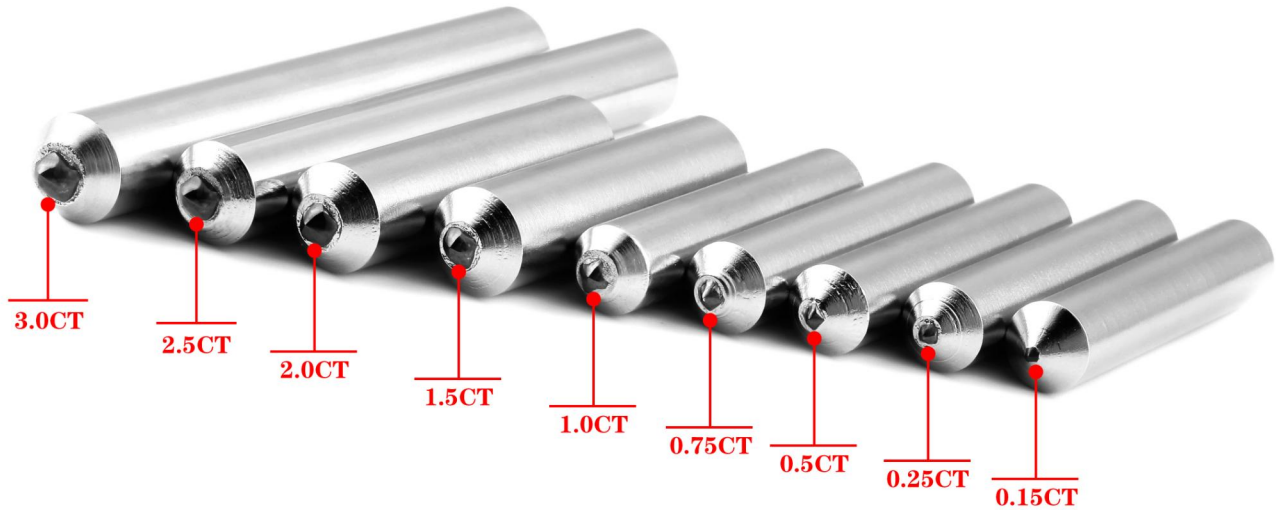

Natural Diamond Quality Grade Standard

SKU	The Diamond Weight	The Diamond Degree	The Grinding Wheel Diameter	Roughness Height
DT2002-250	0.2 Carat	A、B、Cgrade	20-250mm	Ra=0.4-0.1um
DT2003-400	0.3 Carat	A、B、Cgrade	100-400mm	Ra=0.4-0.1um
DT2005-600	0.5 Carat	A、B、Cgrade	300-550mm	Ra=0.8-0.2um
DT2008-750	0.8 Carat	A、B、Cgrade	350-700mm	Ra=0.8-0.2um
CTS1010	1 Carat	A、B、Cgrade	400-750mm	Ra=0.4-0.1um
CTS10102	1.2 Carat	A、B、Cgrade	400-800mm	Ra=0.4-0.1um
CTS1015	1.5 Carat	A、B、Cgrade	500-900mm	Ra=0.4-0.2um
CTS1020	2 Carat	A、B、Cgrade	600-1000mm	Ra=0.4-0.2um
CTS1025	2.5 Carat	A、B、Cgrade	750-1100mm	Ra=0.4-0.2um
CTS1030	3 Carat	A、B、Cgrade	900-1300mm	Ra=0.4-0.2um

Common Shape Product Display

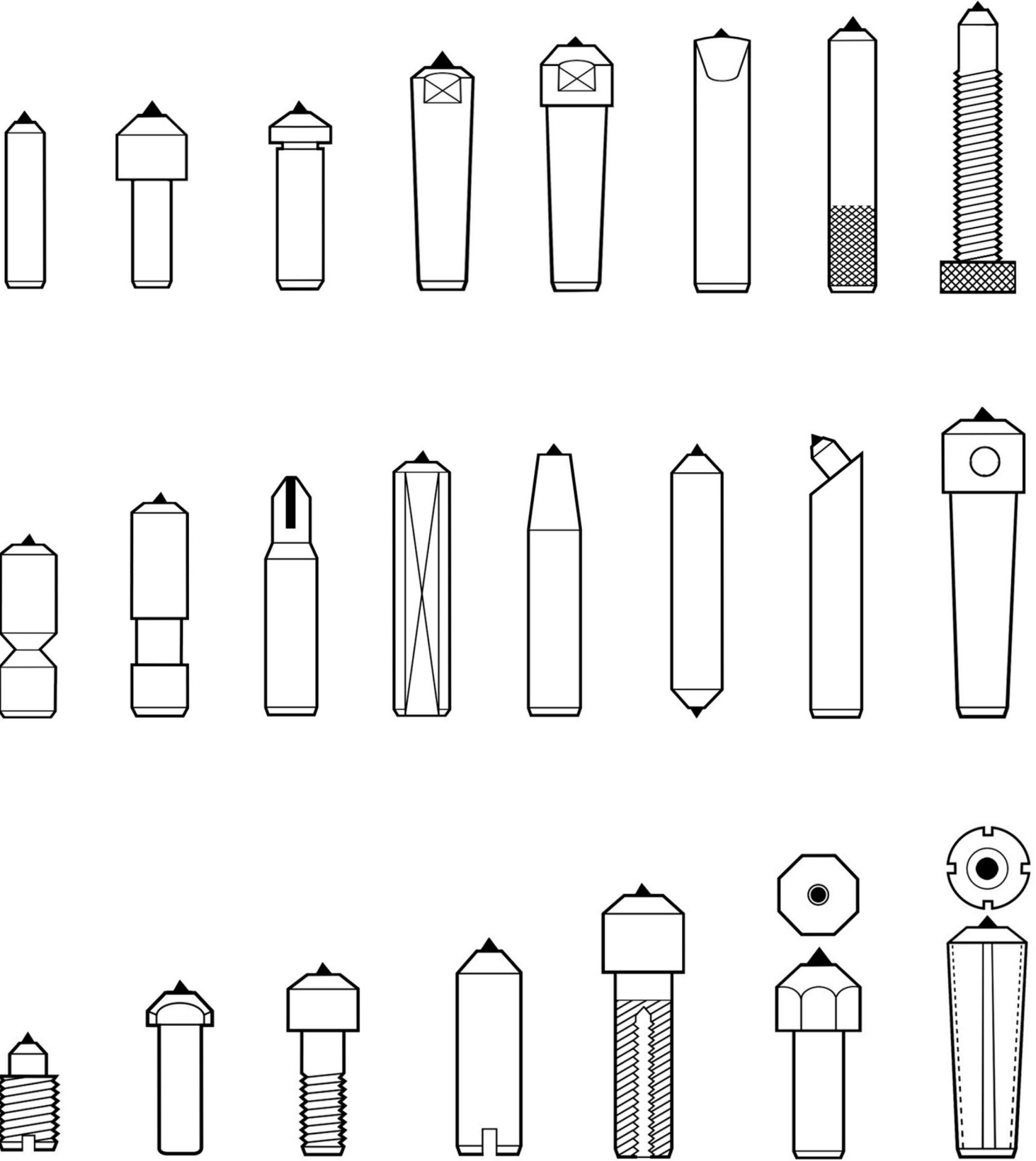

Product Display

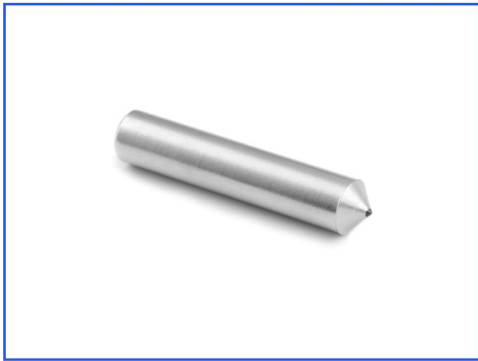

1-1



1-2

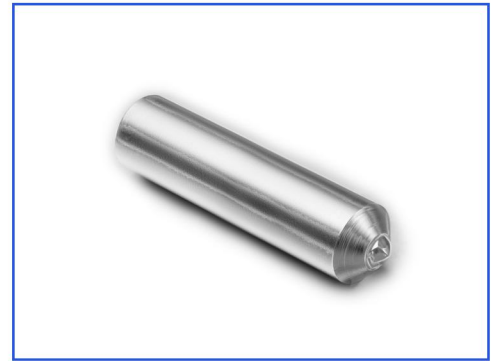

1-3

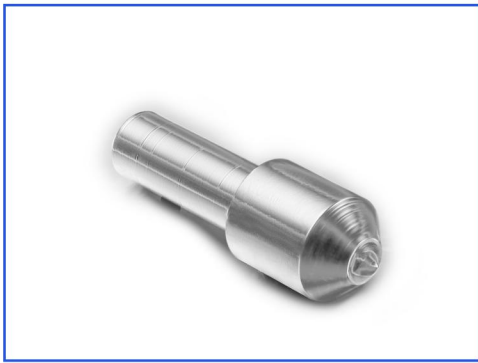

1-4

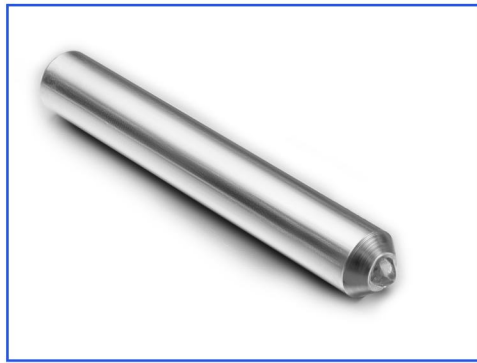

1-5



1-6



1-7



1-8



1-9



1-10



1-11



1-12

Common Model Drawing

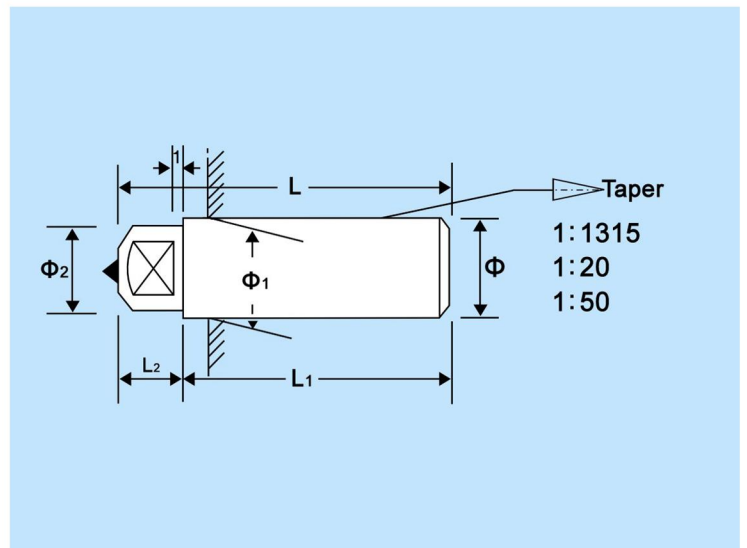
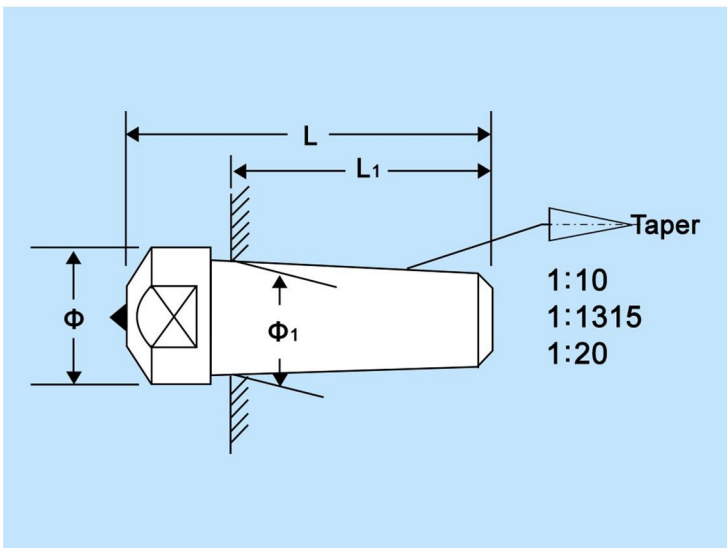
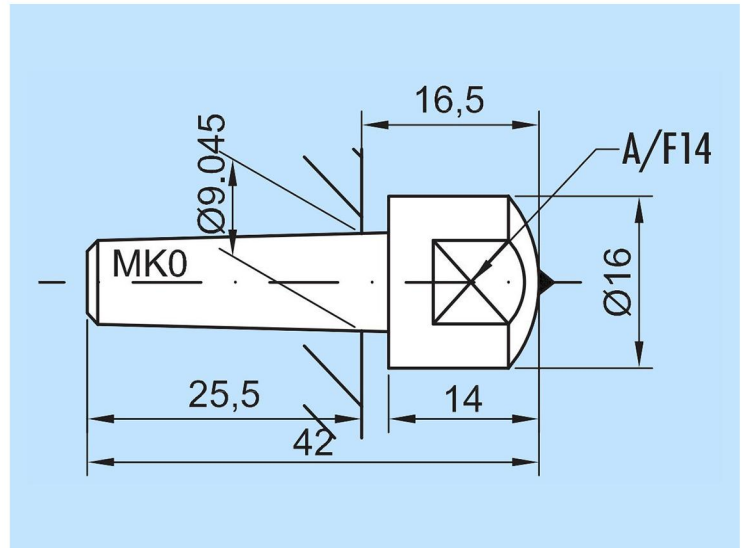
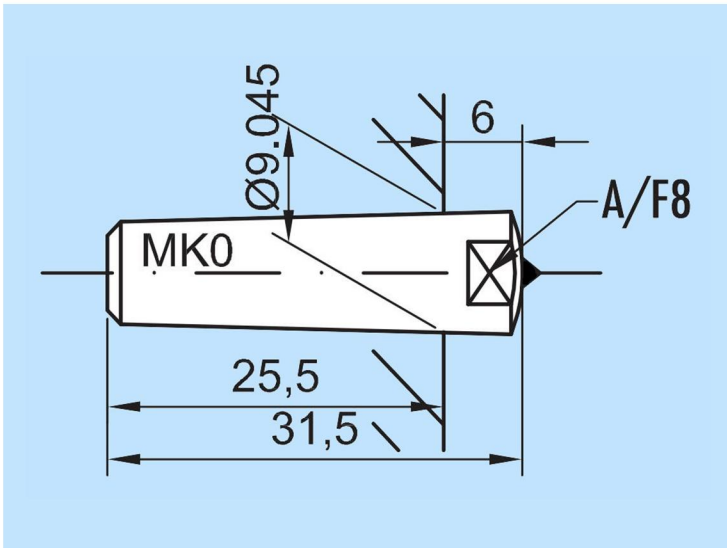
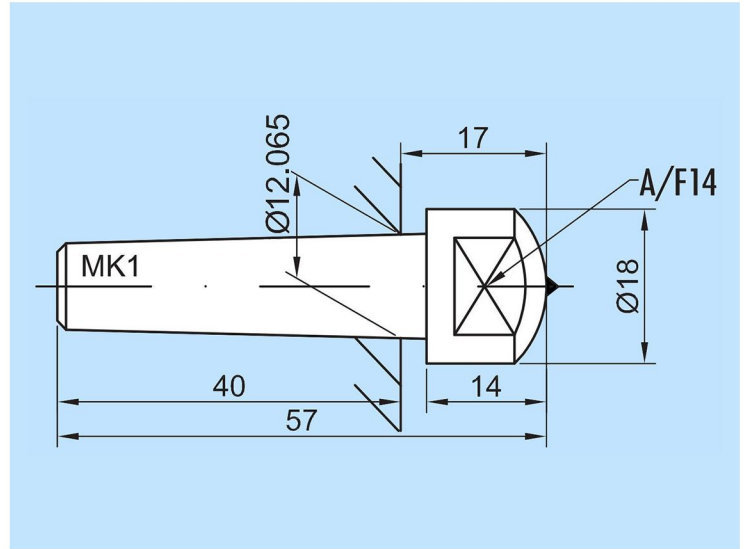
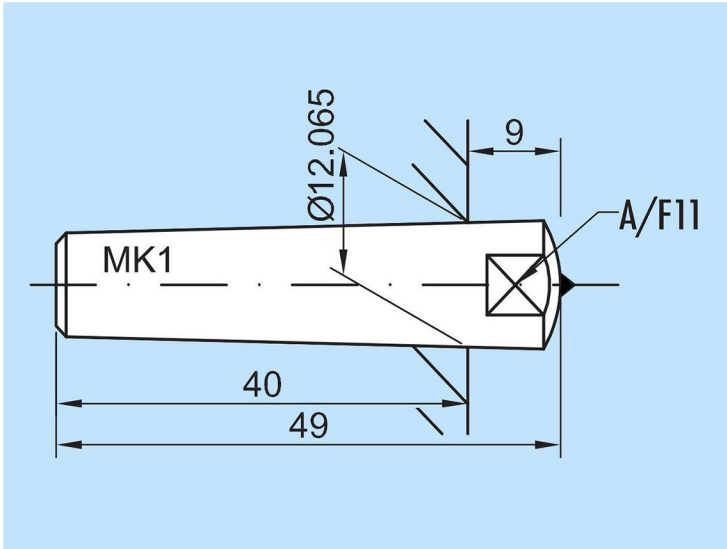

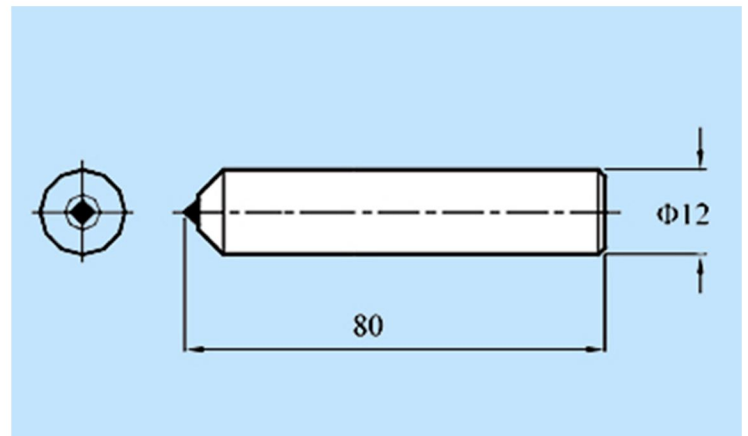
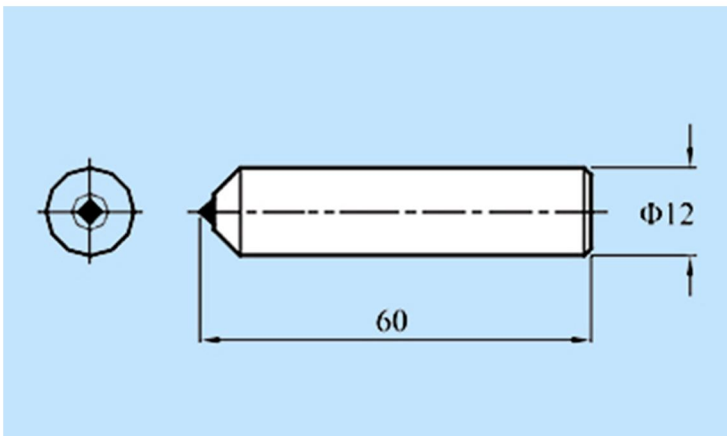
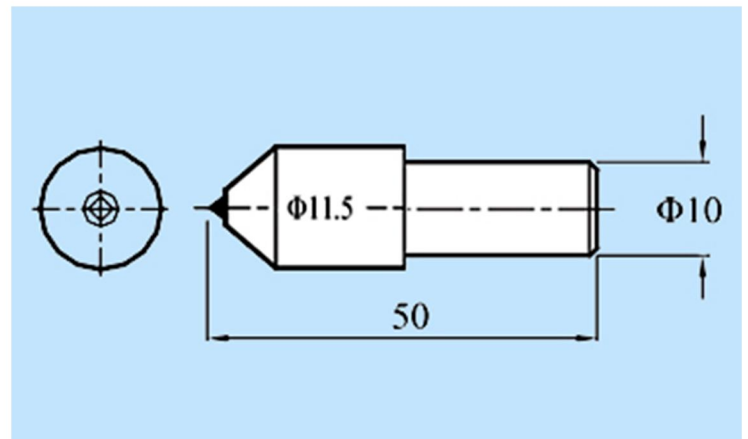
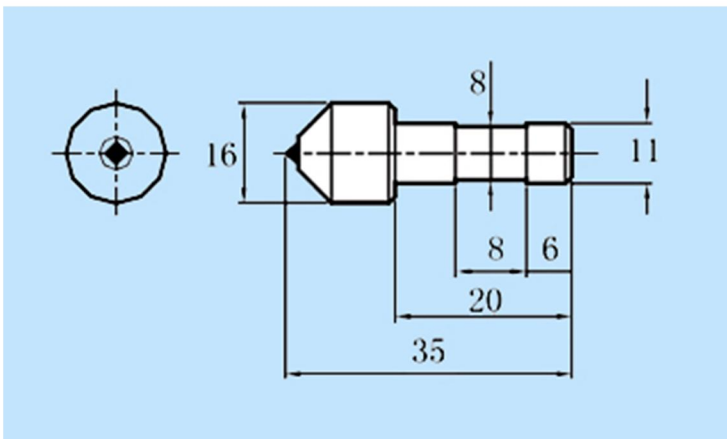
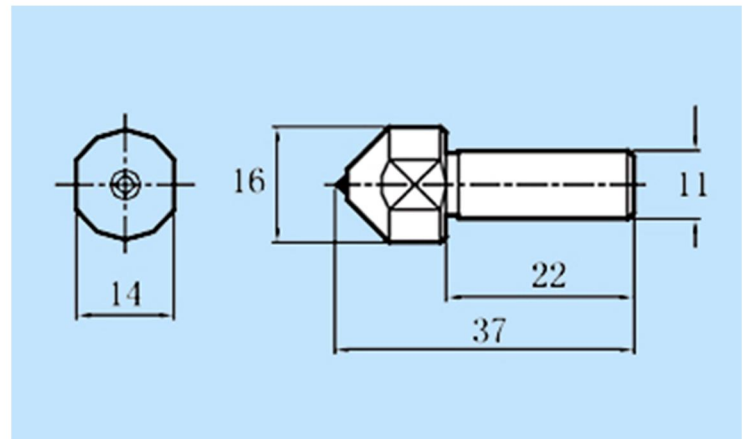
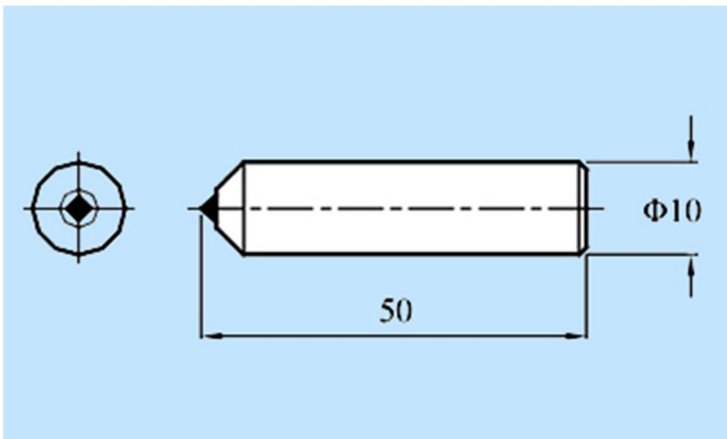
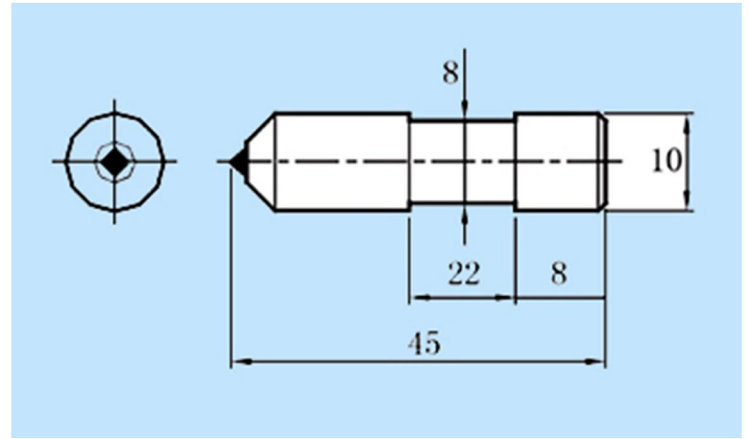
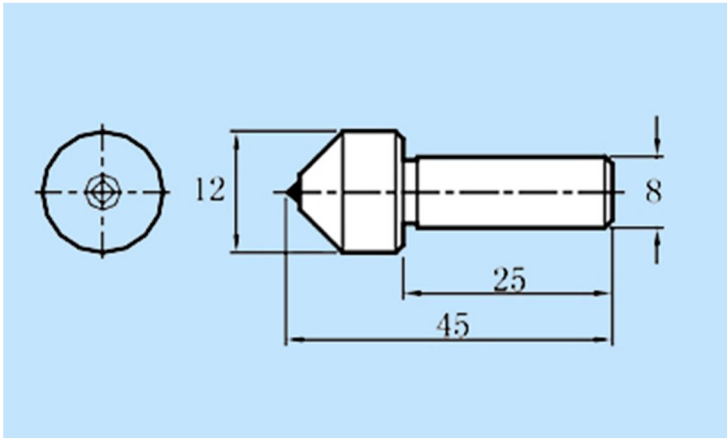

Taper Knife Repaired

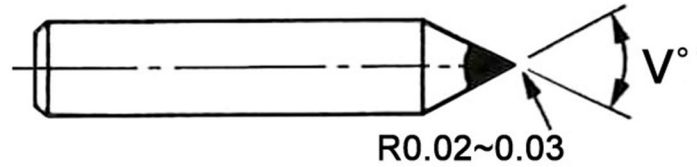

The product USES high quality natural diamond material to grind the diamond into sharp corners. The tip of the sharp corners is perpendicular to the center line of the handle body. It is suitable for shaping and dressing the grinding wheel of precision grinding machines in bearing, mould, tool, electronics and other industries.

SKU	Diamond Angle	Diamond Shape	The Handle Body Size
DA060	60°		Φ3.175×25.4 Φ6.35×25.4
DA075	75°		Φ6.35×50 Φ8×35
DA090	90°		Φ10×50
DV060	60°		Φ6×30
DV090	90°		Φ8×40 Φ10×50
DV110	110°		Φ12×50

Multi Point Diamond Grinding Wheel Dresser

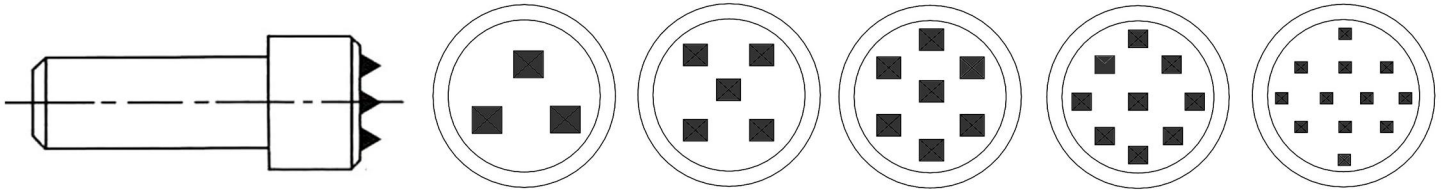

SKU	Diamond Quantity	Suitable Wheel Diameter	Schematic Diagram Of Diamond Material	Use
DM103	3	Φ200~Φ400	high hardness middle hardness low hardness	centerless grinding machine dressing of grinding wheel surface of cylindrical grinder
DM105	5	Φ400~Φ600		
DM107	7	Φ500~Φ750		
DM109	9	Φ750-Φ900		
DM112	12	Φ900-Φ1100		